



CEILING SYSTEMS

[Between us, ideas become reality.™]

INFUSIONS™ Accent Canopies— Solid Polycarbonate and Aluminum Assembly and Installation Instructions

1. DEFINITION

Infusions Accent Canopies feature a selection of finishes in channeled or solid polycarbonate and aluminum. Infusions are available in two sizes: 2 foot by 5 foot and 2 foot by 6 foot. Canopies can be formed to create hills or valleys with either 60° or 90° arcs. Infusions can be suspended individually or they may be linked together. They may be suspended from the building structure or one end may be attached to a wall.

2. DESIGN LIMITATIONS

Infusions panels should always be installed in accordance with all applicable building codes and regulations.

Do not cut holes in or drill through Infusions panels. Doing so may cause the panel to bend in an irregular fashion.

The lowest point of a suspended Infusions panel should be at least 7'-6" above the finished floor surface.

Infusions panels are not approved for exterior application.

Polycarbonate panels can be damaged by exposure to high temperatures. Panel temperature should not be permitted to exceed 100° F after the tensioning cables have been installed. Follow these guidelines for minimum distance from standard light sources:

Lamp Type	Label Wattage	Minimum distance
Halogen FL XL PAR 30	60	14"
Incandescent Bulb	120	15"
Quartz Halogen Work Light	500	23"

3. FIRE PERFORMANCE

Infusions Canopies, as with other architectural features located at the ceiling, may obstruct or skew the planned fire sprinkler water distribution pattern, or possibly delay or accelerate the activation of the sprinkler or fire detection systems by channeling heat from a fire either toward or away from the device. Designers and installers are advised to consult a fire protection engineer, NFPA 13, and their local codes for guidance where automatic fire detection and suppression systems are present.

IMPORTANT: For proper fire performance, do not install polycarbonate panels so that any portion of the panel is suspended directly above any portion of an aluminum panel.

The fire performance of polycarbonate panels is evaluated under the light transmitting plastics requirements of the International Building Code (Chapter 26).

Metal panels are noncombustible.

Contact TechLine at (877) 276-7876, option 1, then 2, then 3, for specific US and Canadian fire performance data.

4. PANEL ASSEMBLY

Kit A: Infusions Canopy Panel Kit

Kit Contents:

- Flat Infusions Panel (1 or 2)
- 24" Aluminum Extrusions (2/panel)
- Tape to attach extrusions
- Cables to form arcs

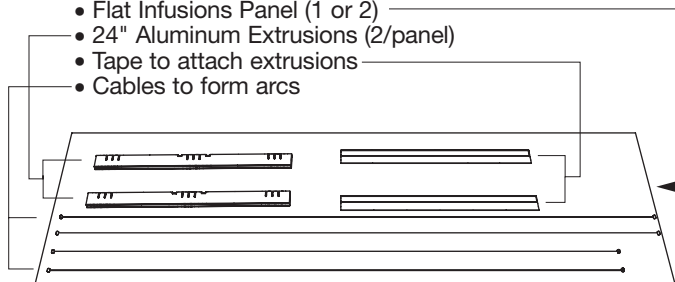

Arc	Tension Cable Length	
	2' x 5'	2' x 6'
60°	58"	69-3/4"
90°	55"	65-3/4"

5. MOUNT EXTRUSIONS

Peel back protective film approximately 8" from ends to apply adhesive strips.

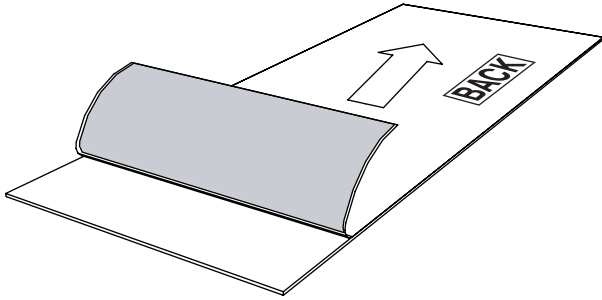

There are different mounting requirements based on the material panels are made from. Please be sure to follow the correct instructions for the panels you've selected.

CAUTION: Use of the correct type and amount of tape is an important part of the fire performance designed into Infusions canopies.

Please call (877) 276-7876, option 114, if you are unsure of the proper tape placement or if you need replacement material.

FOR PANELS MADE OF SOLID POLYCARBONATE AND ALUMINUM

Use only 23" adhesive strips. These strips have a paper liner on one side (which will be the bottom side) and a longer plastic liner (release liner) on the top side.

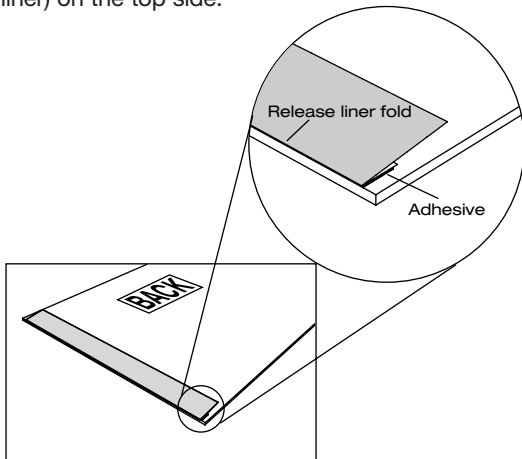

Remove narrow paper liner and apply a 23" adhesive strip to the panel.

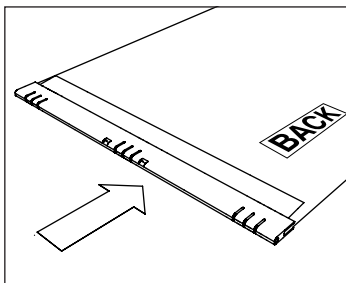

Slide the 24" extrusion over the top of the 23" adhesive strip until it is firmly butting the edge of the panel.

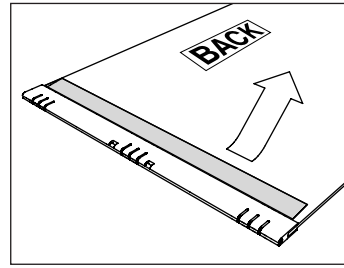

Then, pull the release plastic liner away.

Now your extrusion is mounted. Repeat on other end of panel.

Attachment positions on extrusions

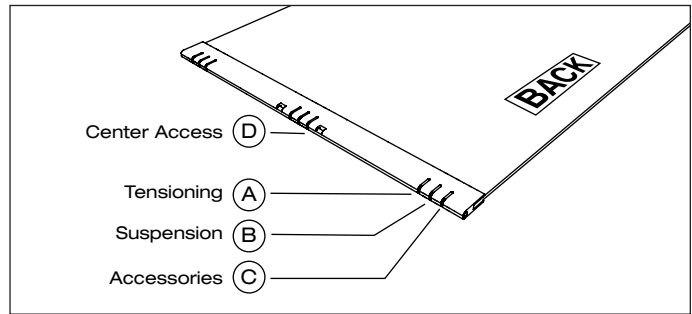

6. CREATING ARCS

Insert ends of tension cables into extrusions at ends of the panel, sliding it into the slot "A" of the three end slots.

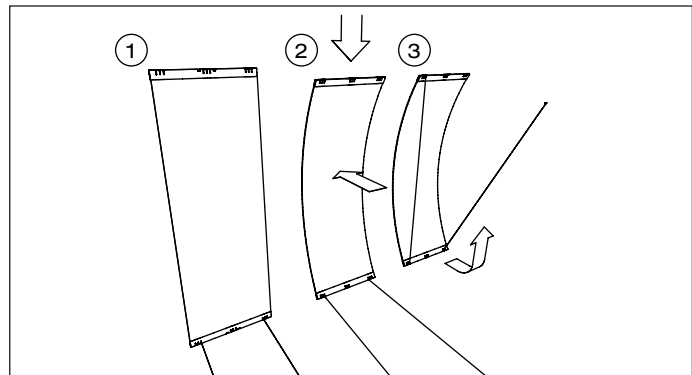
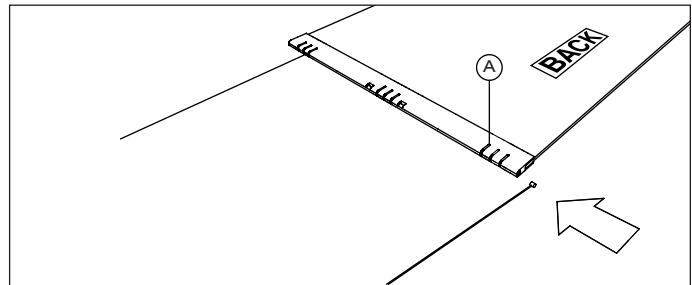

CAUTION: Be careful when tensioning panels.

1. Place one end of the panel on the floor, on a protected surface.
2. Flex the panel by pulling straight down toward the floor and insert ends of cables into tension position A.

Avoid extending body parts over the flexed panel until both tensioning cables are installed. Two people are recommended for this operation.

CAUTION: Only use cables from Kit A for tensioning panels. (Kits B, C & H, shown in section 8, are **only** for hanging panels).

HILL AND VALLEY CONFIGURATIONS

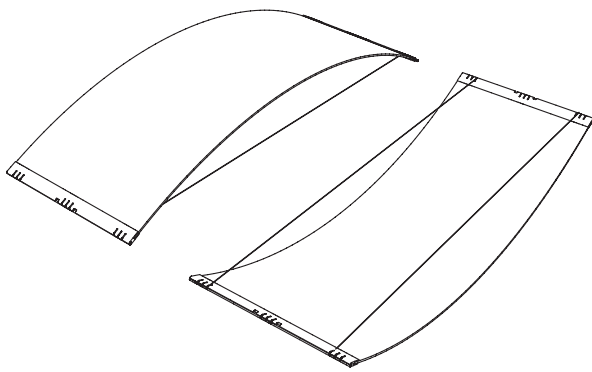

7. PANEL SUSPENSION

The International Building Code requires the attachment of free floating architectural components to be sized for three times the design load. Use the assembled canopy weights provided in this table to select mounting hardware that will meet this requirement:

Material	2' x 5'	2' x 6'
Solid Polycarbonate	21.0 lb	25.0 lb
Aluminum	21.0 lb	25.0 lb

INSTALLATION KITS

Kit B: Standard 8' Hanging Kit – BP7004

Kit Contents:

- (2) Gripper Structure Anchors
- (2) Gripper Adjusters
- (2) Suspension Cables (8')

KEY COMPONENTS AND HOW THEY ARE INSTALLED

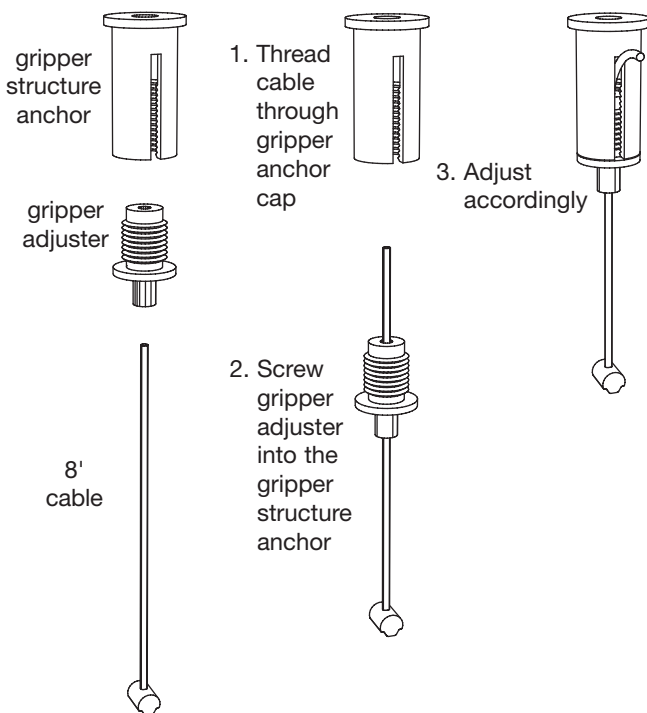

NOTE: Cables must not exit the Gripper Adjusters at an angle. The maximum allowable deflection is 5 degrees. Substitute Kit C or H when cables meet the structure at an angle.

Kit C: Extended 16' Hanging Kit – BP7005

Allows for extended drops from deck and bottom end adjustment of height at panel.

Kit Contents:

- (2) Gripper Structure Anchors
- (2) Gripper Anchor Caps
- (2) Upper Cables (16')
- (2) Gripper Bottom End Assemblies
- (2) Bottom End Cable Adjusters

Kit H: Extended 30' Hanging Kit – BP7010

Same as Kit C except it contains (2) Upper Cables (30')

KEY COMPONENTS AND HOW THEY ARE INSTALLED

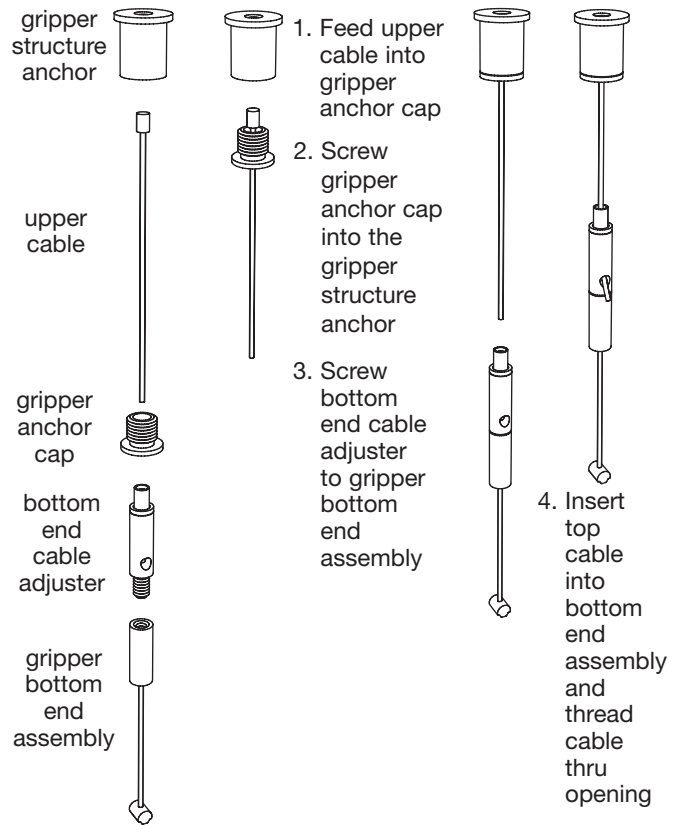

NOTE: Gripper structure anchors have 1/4" - 20NC internal threads that may be used for attachment to structure.

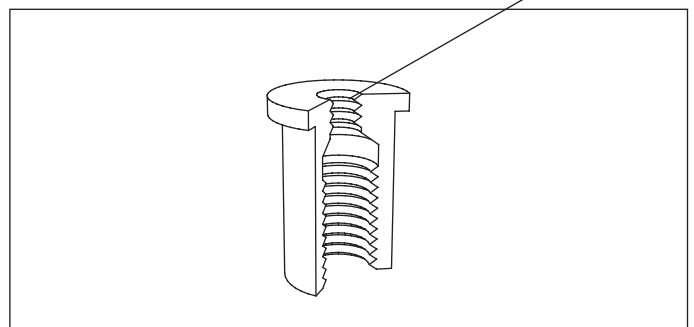

Kit D: Escutcheon Kit – BP7006

Kit Contents:

- (2) Collars with Set Screws
- (2) Escutcheons (2")

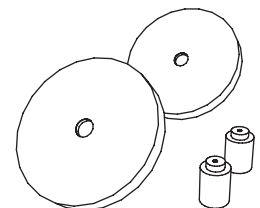

8. INSERTING SUSPENSION CABLES

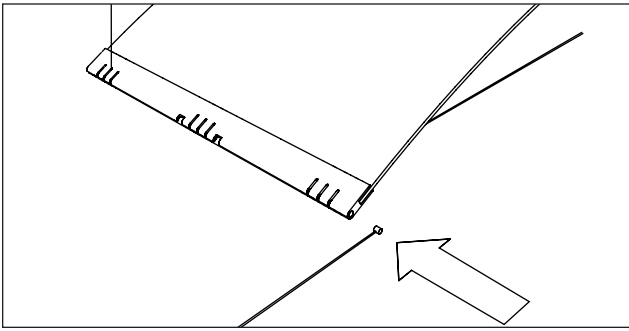

Insert Suspension Cable

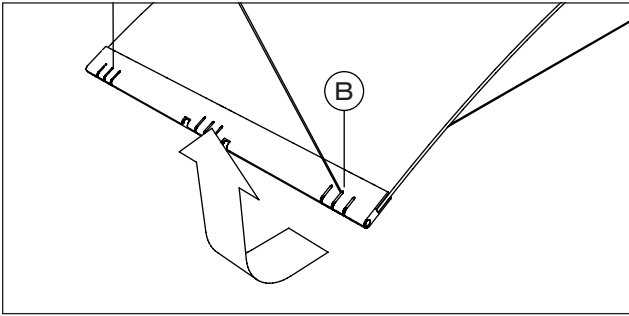

Engage Suspension Cable

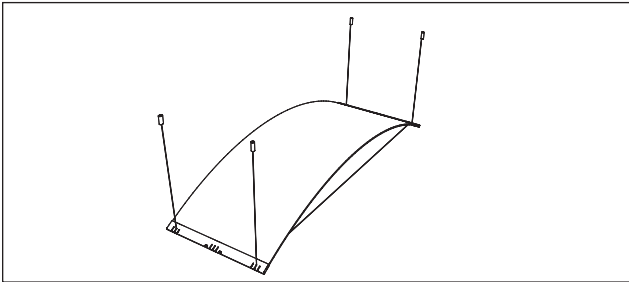

Standard Suspension

9. ATTACHING CANOPIES TO THE STRUCTURE—TWO METHODS

*** NOTE: Components required for attachment to structure are not included in installation hardware kits since they vary by building structure.**

a. Direct to Structure

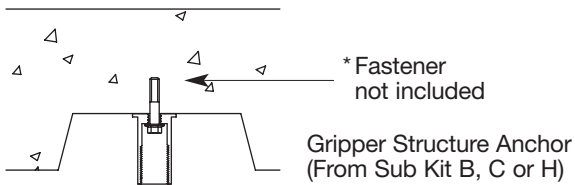

b. Below or through an existing ceiling.

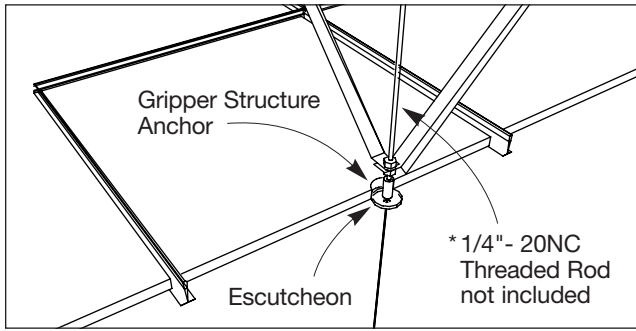

10. LINKED CANOPIES

To link canopies side-by-side, use this hardware kit:

Kit E: Linking Kit – BP7007

Links 2 canopies, side-by-side at one end.

Kit Contents:

- (2) Locking Clips
- (1) Linking Rod (6")
- (1) Spacer

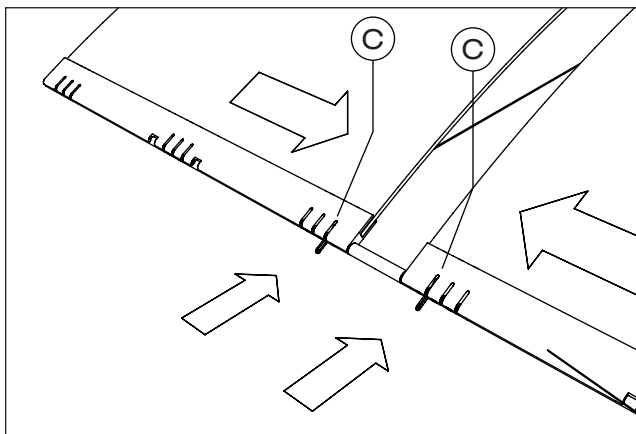
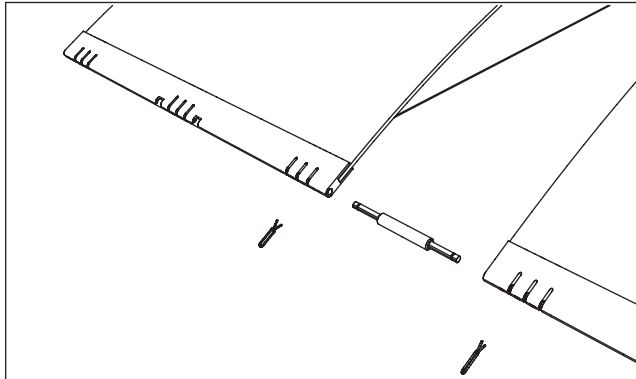
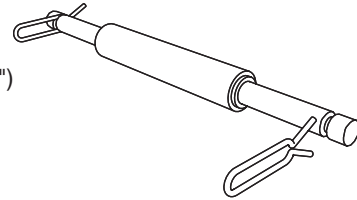

11. WALL MOUNTING OF CANOPIES

Use these hardware kits when one end of the canopy will be attached to the wall.

Kit F: Wall Attachment Kit – BP7008

Anchors canopies side-by-side to wall.

Kit Contents:

- (2) Locking Clips
- (2) Linking Rods (2-1/4")
- (1) Wall Bracket (3")

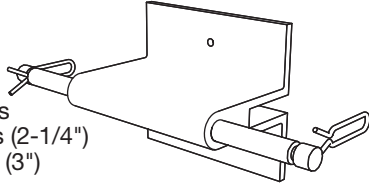

Kit G: Wall End Attachment Kit – BP7009

Used at ends when linking single or multiple canopies.

Kit Contents:

- (1) Locking Clip
- (1) Linking Rod (2-1/4")
- (1) Wall Bracket (1-1/2")

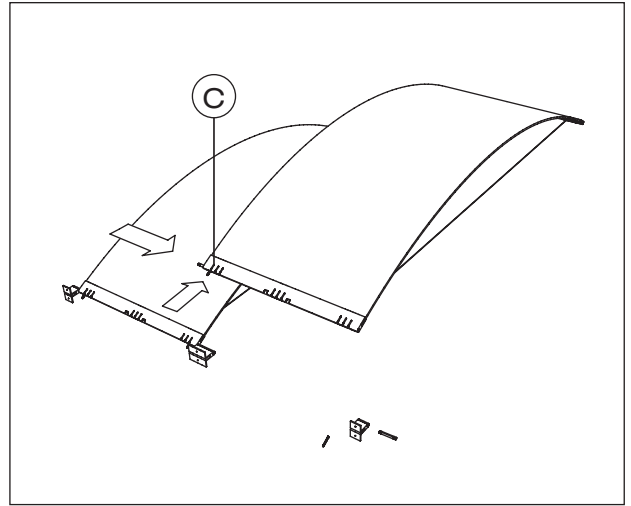
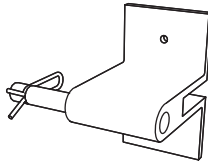

1. Mount wall brackets.
2. Install linking rod and locking clip in one end of the panel.
3. Insert second pin into the wall bracket at the opposite side of the panel.

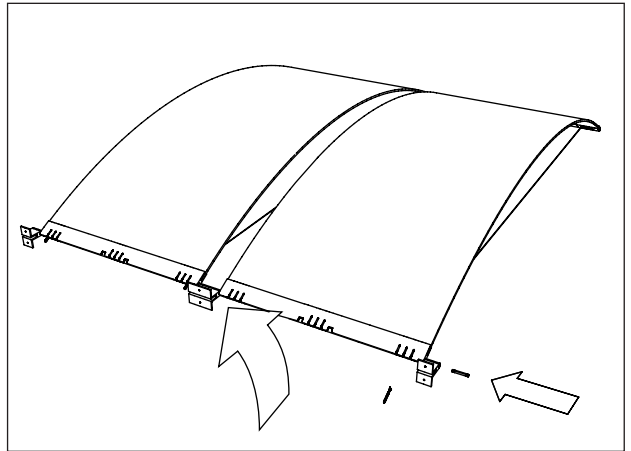

4. Insert pinned end of panel into wall bracket.
5. Push linking pin into wall bracket at opposite side of panel.

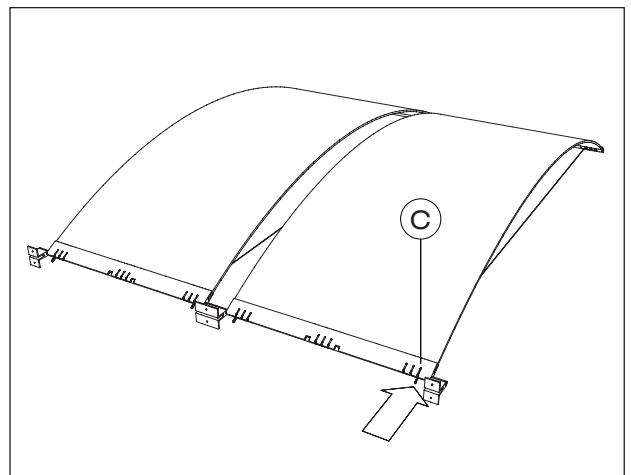

6. Install locking clip.

12. SEISMIC RESTRAINT¹

- The International Building Code allows architectural components to swing freely as long as they will not be damaged or cause damage. Cable lengths less than 20 inches will generate the greatest amount of pendulum reaction during a seismic event, and should therefore be avoided. When it is not practical to use cables greater than 20 inches long allow lateral clearance around the canopies equal to, or greater than, the length of the cable.
- Canopies suspended from cables greater than 20 inches long will swing no more than 8 inches. Restraint of canopies has proven to be ineffective and is not recommended.

¹ Pendulum reaction information is based on full scale testing and computer modeling conducted at the Structural Engineering Earthquake Simulation Lab located at the State University of New York at Buffalo.

13. CLEANING RECOMMENDATIONS

General Recommendations

- Avoid wiping the panel surfaces with abrasive compounds of any type.
- Panels should be handled with clean gloves/hands to avoid fingerprints.
- Static charges that may build up after removing protective masking can be removed by wiping the sheet with a cloth dampened with water.
- Lightly dust with a duster or soft, clean cloth first. Panels may then be cleaned with a small amount of dishwashing liquid in warm water. Keep the cleaning cloth free of grit by frequently rinsing in clean water.

MORE INFORMATION

For more information, or for an Armstrong representative, call 1 877 ARMSTRONG.

For complete technical information, detail drawings, CAD design assistance, installation information and many other technical services, call TechLine™ services at 1 877 ARMSTRONG or FAX 1-800-572-TECH.

For the latest product selection and specification data, visit www.armstrong.com

U.S. Patents Pending, including US Publication No. 2004/0182022.

All trademarks are owned by AWI Licensing Company.

LA-295819-305Solid/Alum

Printed in United States of America

