

Orcal Clip-In 3mm Bevel for use with Orcal 3000 suspension system

This Technical Data Sheet is offered as an aid to the specification of our products and provides information on the tiles manufactured at our European production facilities.

Orcal tiles with Standard Perforation and Microperforation are available with factory applied black acoustic fleece, whilst Orcal tiles with Extra Microperforation are always supplied with factory applied black acoustic fleece.

Orcal tiles can also be made available to order with Premium B15 infill.

Please contact Armstrong Internal Technical Sales Group for further details.

Type Q Clip-In 3mm Bevel – Concealed spring A bar

mm	Plain	Standard Perforation	Microperforation	Extra Microperforation
600 x 600 x 33	BP 2056 M	BP 2067 M	BP 2076 M	BP 2083 M
600 x 300 x 33	BP 2058 M	BP 2068 M	BP 2077 M	BP 2085 M
500 x 500 x 33	BP 2059 M	BP 2069 M	BP 2078 M	BP 2086 M
1200 x 300 x 33	BP 2061 M	BP 2070 M	BP 2079 M	BP 2089 M
1200 x 600 x 33	BP 2062 M	BP 2071 M	BP 2080 M	BP 2087 M
1800 x 400 x 33	BP 2063 M	BP 2072 M	BP 2081 M	BP 2090 M

Type Q Clip-In and Clip-In Swing Down Square Edge – Concealed spring A bar

mm	Plain	Standard Perforation	Microperforation	Extra Microperforation
600x600x33	-	-	-	BP 2094 M
625x625x33	-	-	-	BP 2094 D

Availability of products may vary according to country. Please contact your local Armstrong office for Product range information.

Custom sizes & other modules are available to special order.

Material	Products are manufactured from zinc coated mild steel. Steel gauge dependent on product size.		
Finish	Factory applied polyester powder coat, minimum thickness 55 microns.		
Colour	Standard:	RAL 9010 & 'Global White'	
	Semi-Standard:	RAL 9001, RAL 9002, RAL 9006, RAL 9007, RAL 9016	
	Other colours are available as special order items.		
Gloss	RAL 9010 :	20%	
	Global White :	20%	
	Semi-Standard :	30%	
	Measured in accordance with ISO 2813:2000, use 60° geometry.		

Light Reflectance	Pattern	RAL 9010	Global White
	Plain (unperforated)	87%	77%
	Extra Microperforation with black fleece	85%	76%
	Microperforation with black fleece	71%	63%
	Standard Perforation with black fleece	75%	68%
	Measured in accordance with ASTM 1477-98.		

Perforations	Standard Perforation 2.5mm dia.holes 16% open area	Microperforation 1.5mm dia. holes 22% open area	Extra Microperforation 0.7mm dia. holes 1% open area
	Other perforations are available as special order items. Please contact ITS for options and capabilities.		

All measurements are in millimetres.

Suspension Systems

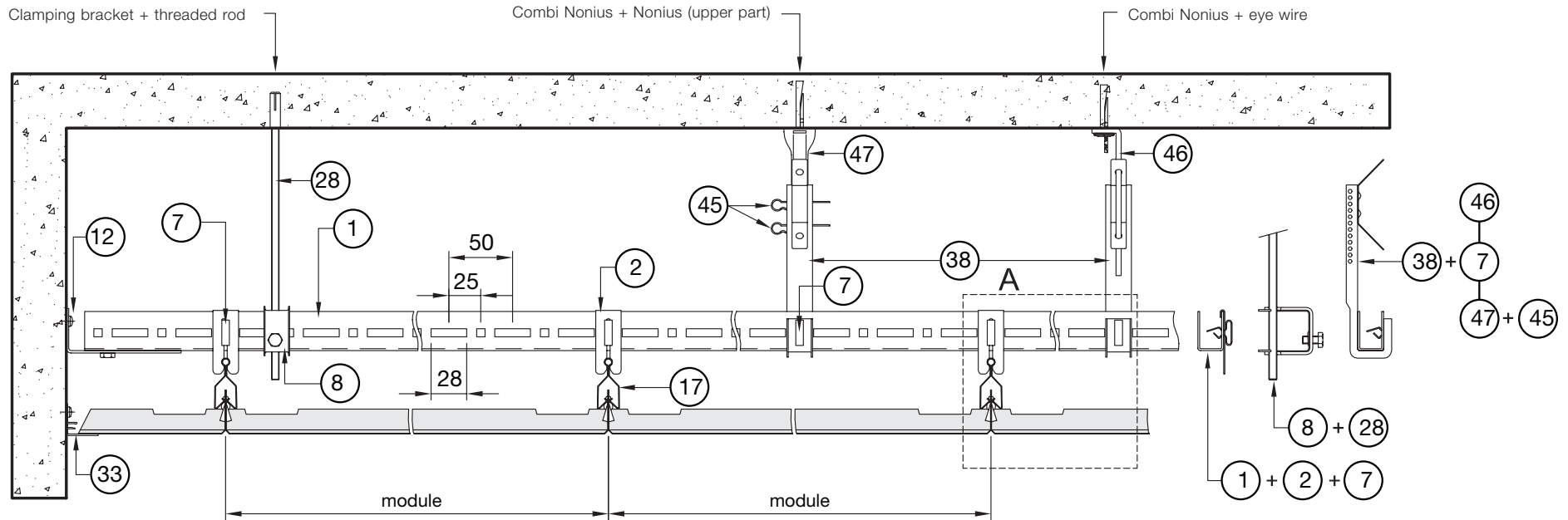

A Type Q

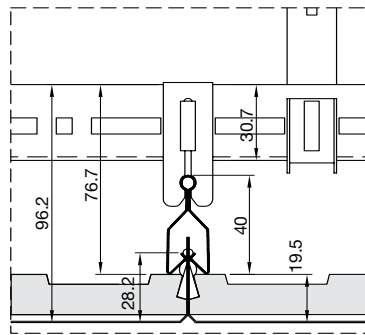
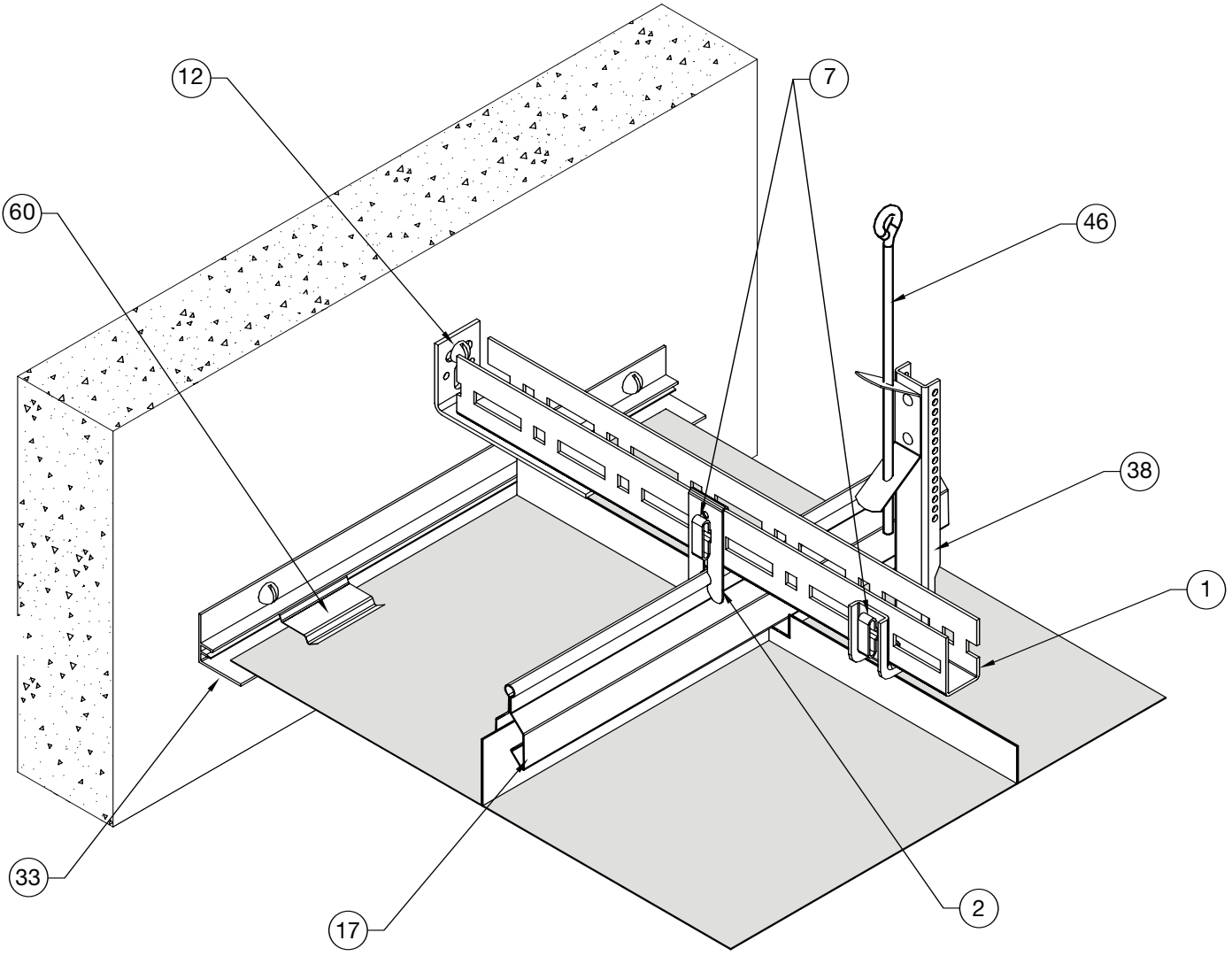

Fig. Item No. Quantity
100m² area

①	BPM 300100	67 lm	②⑧	BPM 311099/...	56 pc
②	BPM 300105	112 pc	③③	BPM 215013	40 lm
⑥	BPM 300119	18 pc	③⑧	BPM 300166	56 pc
⑦	BPM 300120	203 pc	④⑤	BPM 300036	112 pc
⑧	BPM 300121	56 pc	④⑥	BPM 311030	56 pc
⑪	BPM 300138	42 pc	④⑦	BPM 300071/...	56 pc
⑫	BPM 300140	14 pc	⑥⑩	BPM 311081	133 pc
⑰	BPM 311022	167 lm	⑥②	BPM 311028	1 pc

Layout & Grid components (Method 1)



Layout & Grid components (Method 2)

600 x 600mm module

Dimension A	600mm
Dimension B	1500mm*
Dimension C	1200mm*

*Recommended suspension configuration. The maximum dimension from perimeter walls to the first hanger position should not exceed 400mm.

Fig.	Item No.	Description
①	BPM 311022	System 3000 Spring Bar
②	BPC 3000	38 x 19 Primary Channel
③	BPC 1502	Continental Hanging Bracket
④	BPT 1919HC	19 x 19 Angle Trim
⑤	BPC 2040	Perimeter Trim
⑥	BPC 1803	Cut Tile Wedge

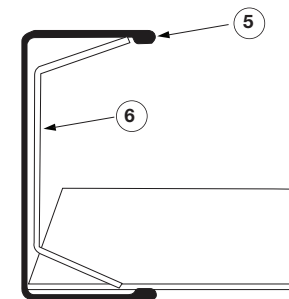
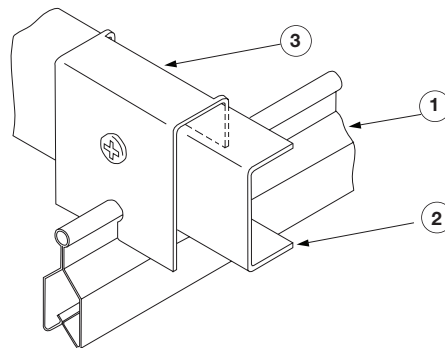
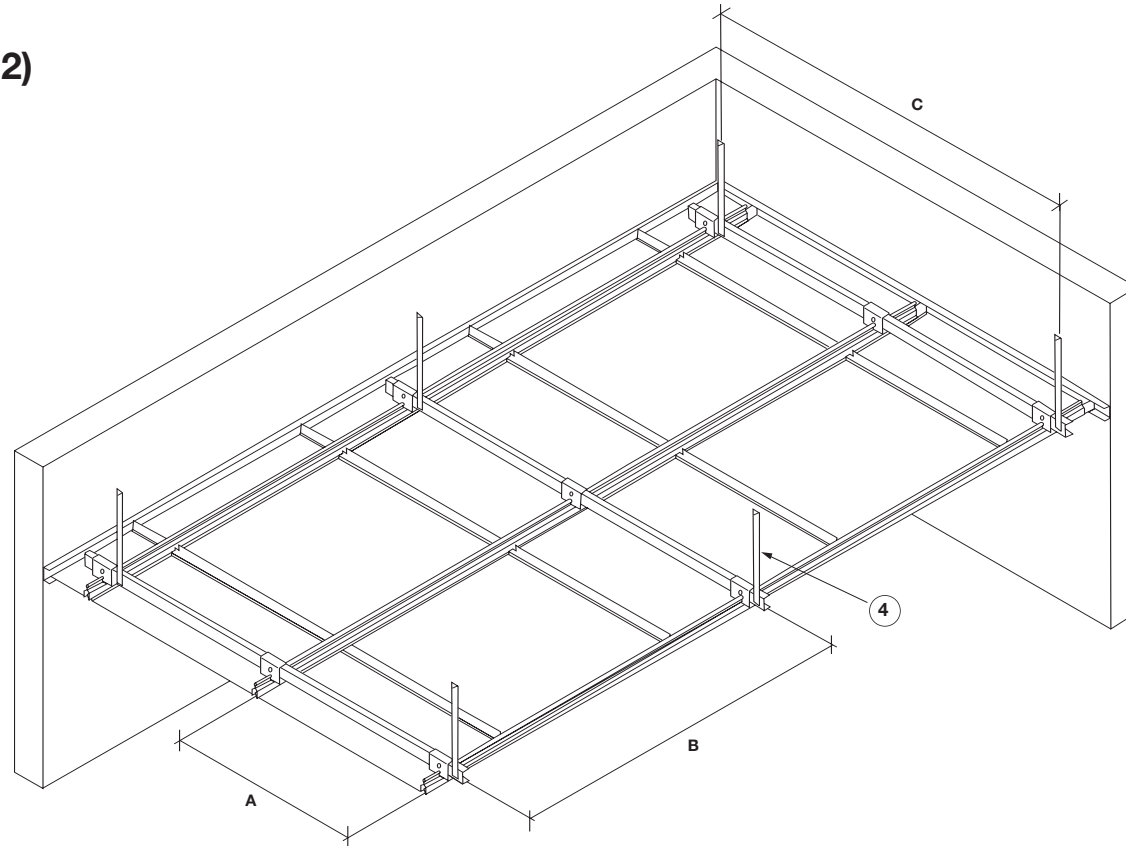

Perimeter Solutions

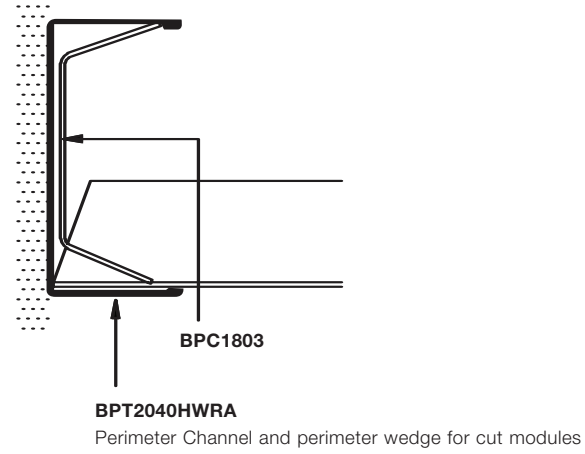
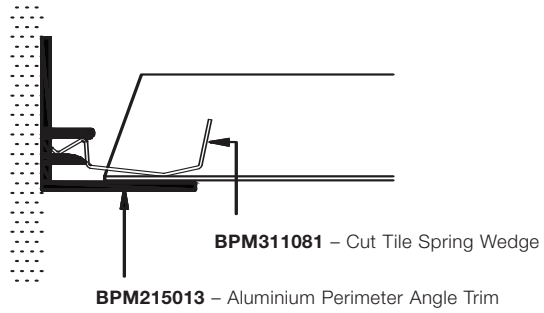

Alternative – Full tile modules with plasterboard perimeter using Axiom:

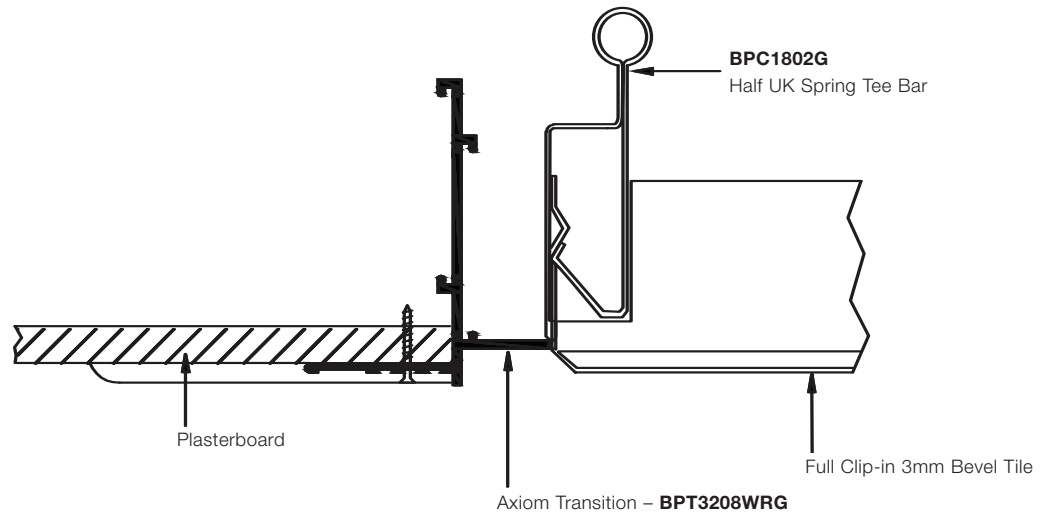
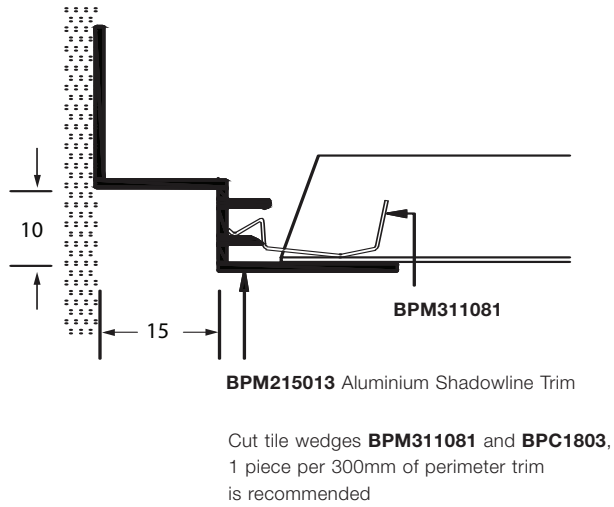

Acoustic Performance**Sound Absorption (α_w)**

	Acoustic fleece	Premium B15 infill
Standard Perforation	0.70 (L)	0.60 (H)
Microperforation	0.75 (L)	0.60 (H)
Extra Microperforation	0.55 (L)	0.65 (L)

No acoustic infill (α_w)

Plain 0.10(L)

Room-to-room sound attenuation (Dncw)

	Acoustic fleece	Premium B15 infill
Standard Perforation	20 dB	41 dB
Microperforation	20 dB	41 dB
Extra Microperforation	30 dB	40 dB
Plain	-	47 dB

No acoustic infill (Dncw)

Plain 44 dB

A range of acoustic infills is available to achieve various acoustic performance levels. For further information please contact Armstrong Internal Technical Sales Group.

Tile Loading

Orcal tiles are capable of directly supporting limited additional loads from small service fittings. The maximum total uniformly distributed static load that can be applied to the rear of a 600x600mm tile should not exceed 3kg. The use of a pattsess is recommended to distribute the load and to minimise face deflection of the tiles. Loads greater than 3kg should be independently suspended or supported from the primary grid. The maximum distributed static load that can be carried by the grid system should not exceed 10 kg/m². (Applies to standard ladder formation with main runners and hangers at 1200mm centres.)

Services Integration

Orcal tiles can be supplied with factory produced cut outs and apertures for the integration of lighting fittings, air grilles, sprinklers, and other building services equipment.

Handling and Storage

Ceiling components should be stored under conditions of use in a dry interior location and should remain in cartons until installation. Cartons should be stacked and oriented as shown on the carton. Care must be exercised during handling and opening of cartons to avoid damage. The use of soft cotton gloves is recommended for tile installation.

Environmental

Our metal ceilings have an average of 25% recycling content. ISO 14001: 2004 certified process.

Thermal Conductivity

(λ) W/mK
 50.0 : Steel
 0.04 : Acoustic fleece

Humidity Exposure

Not greater than 70% RH @ 16°-23°C for long term exposure. Not greater than 95% RH for short term exposure during building site installation.

Fire Reaction**Plain without acoustic infill**

EEA Euroclass A1 (RAL 9010)

EEA Euroclass A2-s2, d0 (other colours)

No acoustic infillPerforated $\phi \leq 2.5$ mm

EEA Euroclass A1 (RAL 9010)

EEA Euroclass A2-s1, d0 (other colours)

With acoustic Fleece, ABBTF pad or B15 infillPerforated $\phi \leq 2.5$ mm (acoustic fleece)

EEA Euroclass A2-s2, d0

Perforated $\phi \leq 2.5$ mm (ABBTF pad)

EEA Euroclass A1

Perforated $\phi \leq 2.5$ mm (Premium B15 infill)

EEA Euroclass A2-s1, d0

Weight5 kg/m² – Steel tile**Field Cutting**

Orcal tiles can be cut using tin snips, electric sheet metal shears or band/jig saw. Care must be exercised to avoid damage to the painted surface, bending or distortion of the tiles.

Cleaning

Dust should be removed from the painted surface by wiping with a clean soft cloth. More stubborn marks should be removed with a mild household detergent in warm water. Excessive use of water should be avoided. The use of abrasive cleaners or scrubbing of the painted surface is not recommended.

Quality Standard

Armstrong is a certified ISO900:200 Quality Assumed Manufacturer. All tiles and products are manufactured to tolerances and quality standards in accordance with EN13964. Where differences exist between this and any expressed or implied architectural specifications or requirements than Armstrong's manufacturing standards will prevail unless stated otherwise.

Detailed NBS K40 specifications are available for these products, please contact Armstrong Internal Technical Sales Group for further details. All product specifications are subject to modifications without prior notice.

United Kingdom**Republic of Ireland**

Armstrong World Industries Ltd.
 Building Products Division
 Armstrong House
 38 Market Square
 Uxbridge UB8 1NG

0800 371849 (UK) **FREEPHONE**

1800 409002 (ROI)

Fax: +44 (0) 1895 274287

sales-support@armstrong.com

www.armstrong-ceilings.co.ukwww.armstrong-ceilings.ieOther markets: www.armstrong-europe.com